

Manual de Orientações

1



FIRST FLUSH FFF-150

***Edição 2
Fevereiro/2021***

www.auxtrat.com.br



Modelo: *FIRST FLUSH COM FILTRO* *FFF-150*

O First Flush Automatizado com Filtro Separador de folhas FFF-150, descarte de primeira água, foi desenvolvido pela Auxtrat, para complementar a linha de equipamentos para coleta e aproveitamento de água da chuva.

Acoplado ao filtro separador de folhas, este equipamento tem a função de descartar as sujeiras depositadas no telhado após algumas horas ou dias sem chuva. Sujeiras estas compostas por fuligem, poeiras, fezes de pássaros e acidez da água da chuva que no primeiro minuto faz limpeza na atmosfera, arrastando para baixo as impurezas suspensas no ar.

2



ATENDE A NBR 15527 E CERTIFICAÇÃO LEED.

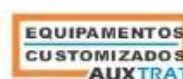

FUNCIONAMENTO:

O painel do equipamento ao ligar sua chave seletora aparecerá na tela a informação do funcionamento do equipamento com o tempo de 5 minutos de abertura e fechamento de deságue do First Flush Automatizado Auxtrat. O botão central é o reset do equipamento caso seja necessário.

A cada 24 hs após seu acionamento, que se dá através do sensor de nível dentro do compartimento central, o equipamento fará uma nova abertura do descarte inicial da água da chuva.

FLUXO DE ÁGUA
5 MINUTOS

A ÁGUA É DESCARTADA PELO FIRST FLUSH

FLUXO DE ÁGUA
APÓS 5 MINUTOS

A ÁGUA É DESTINADA PARA O FILTRO
PENEIRA

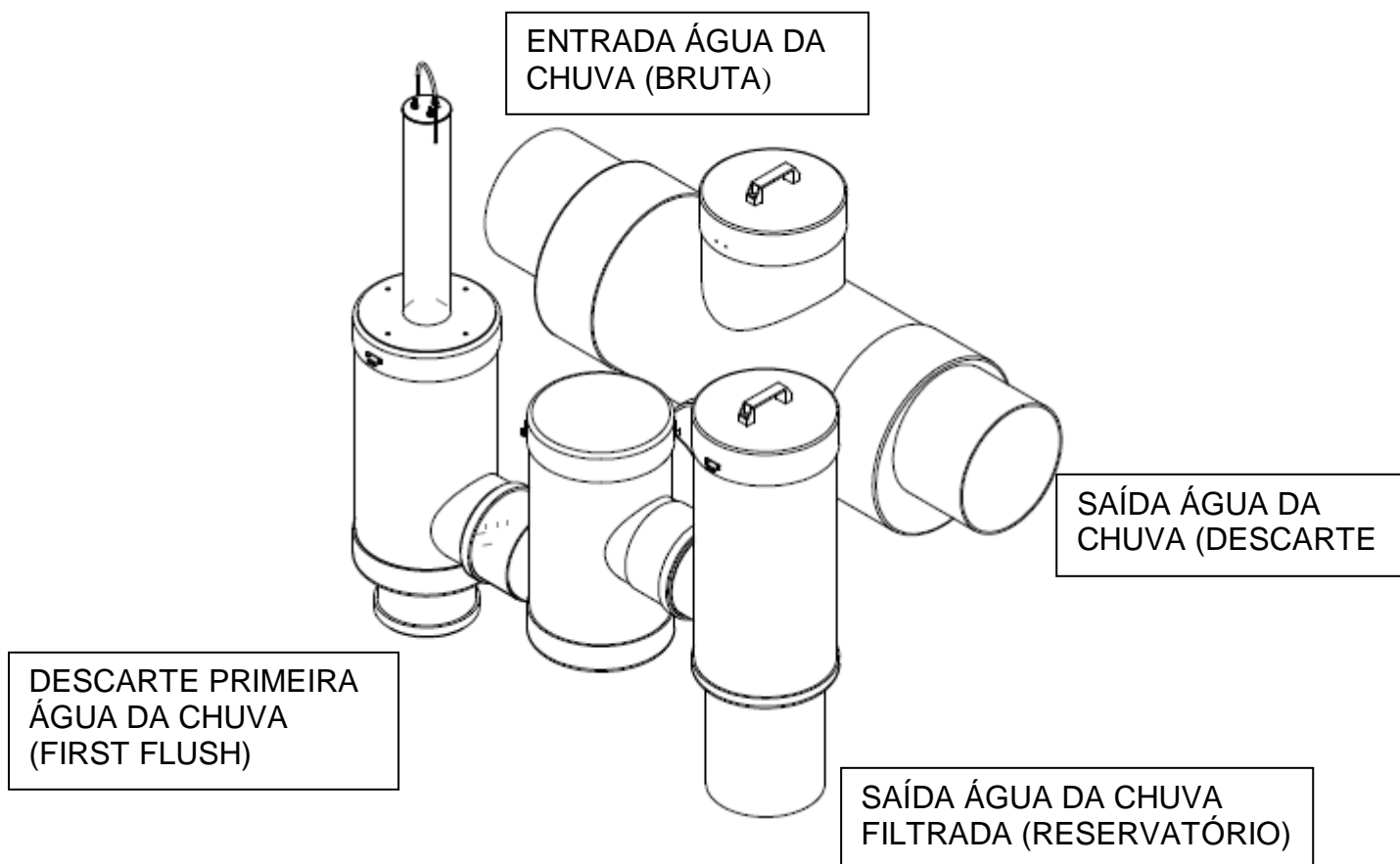

BITOLAS E DIMENSIONAL

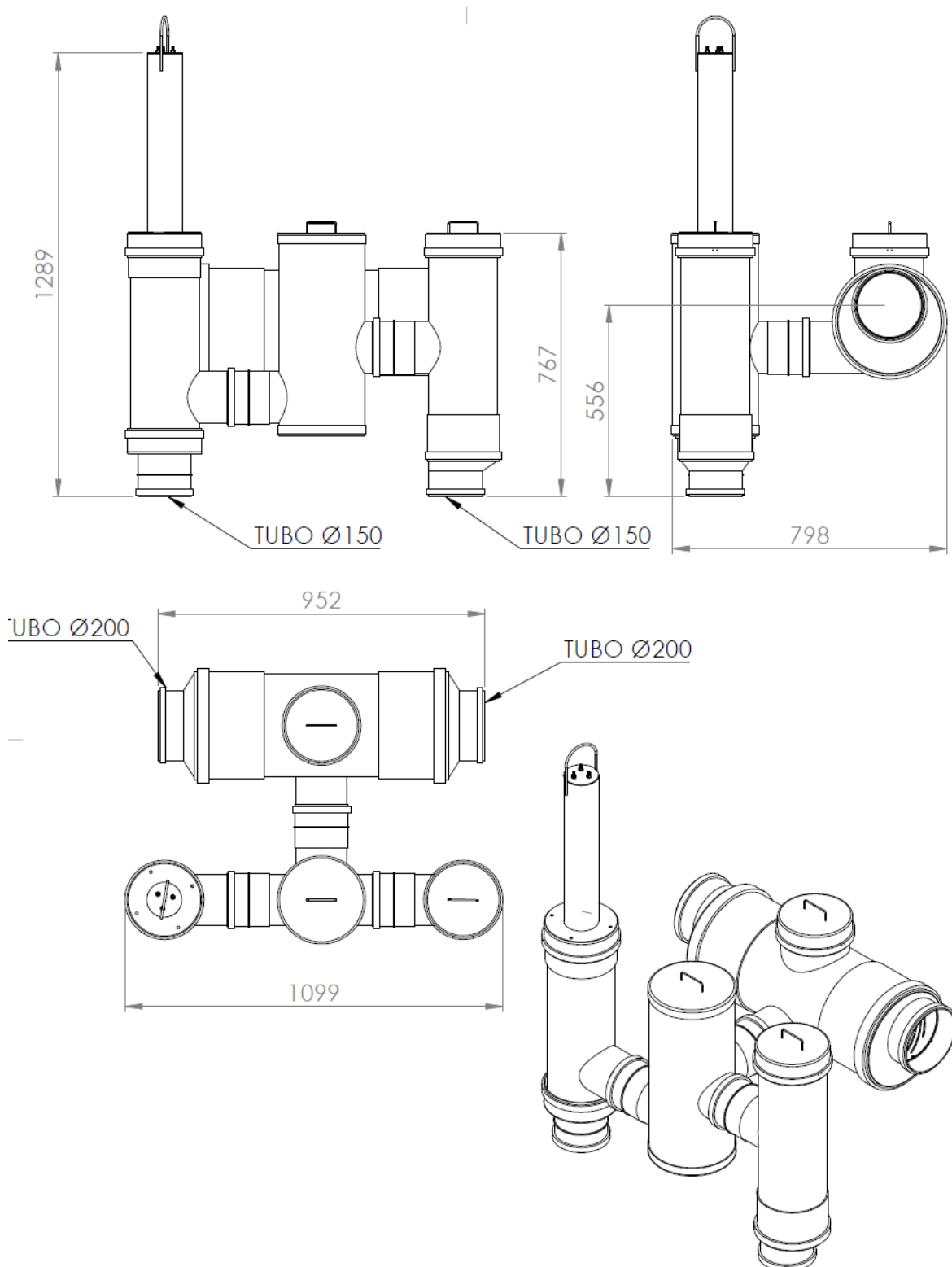

4

DIMENSIONAIS: 1410(C) x 936(L) x 1282(H) mm
PESO APROXIMADO: 92Kg



LIMPEZA E MANUTENÇÃO

A) Do duto do First Flush



B) Do filtro separador de folhas, primeira separação

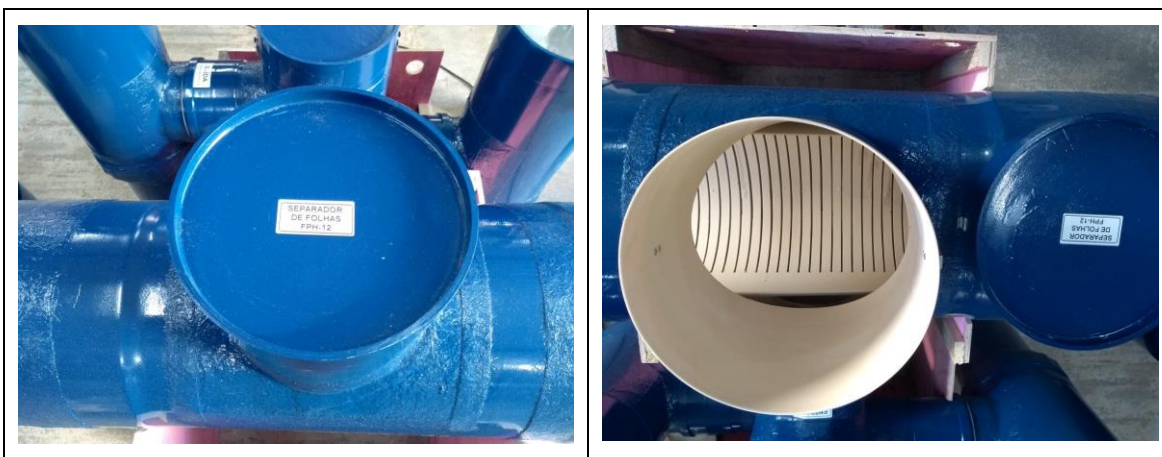

C) Do filtro peneira





CERTIFICADO DE GARANTIA

Todo equipamento fabricado pela AUXTRAT é testado individualmente e garantido contra defeitos de fabricação ou matéria prima, pelo prazo comprovado de 12 meses a partir da data de aquisição, atestada pela respectiva Nota Fiscal.

A garantia compreende somente a recuperação e/ou substituição gratuita da parte/peça defeituosas. São de responsabilidade do comprador a entrega e retirada da parte/peça considerada defeituosa, sem ônus à fábrica.

A respectiva garantia não cobre: instalação, utilização e manutenção indevida; danos causados por culpa ou inexperiência do operador/instalador ou de terceiros e fatores climáticos adversos.

Equipamento sujeito a vazamento em função de operar água com pressão durante o processo de instalação, operação e manutenção. Esta garantia não cobre danos causados por mau posicionamento de instalação que porventura possa danificar revestimentos de gesso, pinturas, pisos de madeira, etc.

FÁBRICA: Auxtrat Indústria e Comércio de Equipamentos Para Saneamento Ambiental Ltda.

CNPJ: 05.205.974/0001-25 **IE:** 254.832.121

Rua Águia, 210 – Costa e Silva – CEP 89220-140 – Joinville – SC

Fone/Fax: (47) 3473-7796

www.auxtrat.com.br

